

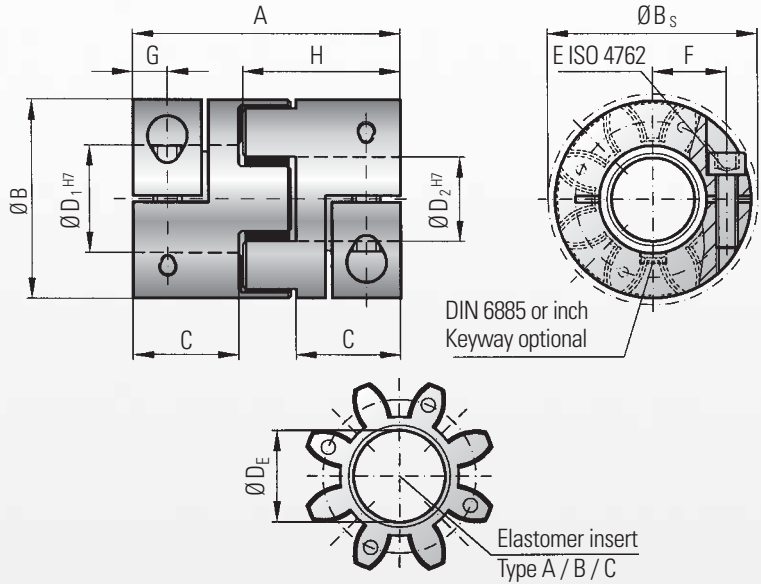

MODEL EK2

BACKLASH FREE ELASTOMER COUPLINGS



with clamping hubs

Properties:

- easy assembly
- concentrically machined hubs
- vibration damping
- electrically insulating
- backlash-free
- press-fit design

Material:

Clamping hub: up to series 450 high strength aluminum, from series 800 and up steel
Elastomer insert: precision molded, wear resistant, and thermally stable polymer

Design:

Two coupling hubs are concentrically machined with concave driving jaws

*Speeds:

Over 10,000 rpm a finely balanced version is available

Tolerance:

On the hub/shaft connection 0.01 to 0.05 mm

Model EK 2	Series																	
	20			60			150			300			450			800		
Type (Elastomer insert)	A	B	C	A	B	C	A	B	C	A	B	C	A	B	C	A	B	C
Rated torque (Nm) T_{KN}	17	21	6	60	75	20	160	200	42	325	405	84	530	660	95	950	1100	240
Max. torque** (Nm) T_{Kmax}	34	42	12	120	150	35	320	400	85	650	810	170	1060	1350	190	1900	2150	400
Overall length (mm) A	66			78			90			114			126			162		
Outer diameter (mm) B	42			56			66.5			82			102			136.5		
Outer diameter with screwhead (mm) B_s	44.5			57			68			85			105			139		
Mounting length (mm) C	25			30			35			45			50			65		
Inner diameter range H7 (mm) $D_{1/2}$	8 - 25			12 - 32			19 - 36			20 - 45			28 - 60			35 - 80		
Inner diameter max. (elastomer) (mm) D_E	19.2			26.2			29.2			36.2			46.2			60.5		
Mounting screw (ISO 4762/12.9)	M5			M6			M8			M10			M12			M16		
Tightening torque of the mounting screw (Nm) E	8			15			35			70			120			290		
Distance between centers (mm) F	15.5			21			24			29			38			50.5		
Distance (mm) G	8.5			10			12			15			17.5			23		
Hub length (mm) H	39			46			52.5			66			73			93.5		
Moment of inertia per Hub (10^{-3} kgm^2) J/J_2	0.016			0.05			0.13			0.4			0.9			9.5		
Approx. weight (kg)	0.15			0.35			0.6			1.1			1.7			10		
Speed* (rpm)	19000			14000			11500			9500			8000			4000		

Information about static and dynamic torsional stiffness as well as max. possible misalignment see page 5

1 Nm = 8.85 in lbs

** Maximum transferable torque of the clamping hub depends on the bore diameters (bore/shaft clearance 0.01 mm to 0.05 mm shaft oiled)

Series	Ø 8	Ø 16	Ø 19	Ø 25	Ø 30	Ø 32	Ø 35	Ø 45	Ø 50	Ø 55	Ø 60	Ø 65	Ø 70	Ø 75	Ø 80
20	20	35	45	60											
60		50	80	100	110	120									
150			120	160	180	200	220								
300			200	230	300	350	380	420							
450					420	480	510	600	660	750	850				
800							700	750	800	835	865	900	925	950	1000

Higher torque through additional key possible.

Ordering example

EK2 / 60 / A / 19.05 / 24 / XX

Model
Series
Type Elastomer insert
Bore Ø D1 H7
Bore Ø D2 H7
Non standard e.g. finely balanced

All data is subject to change without notice.