

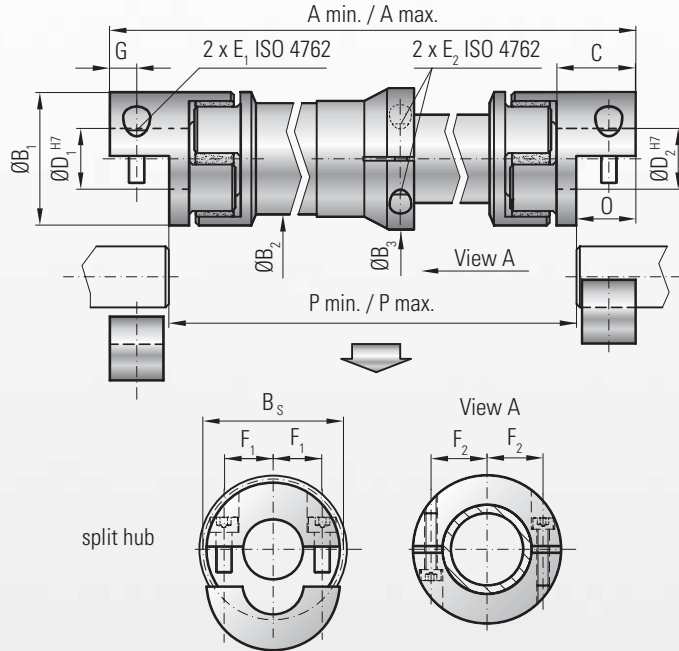

MODEL EZV

BACKLASH FREE LINE SHAFTS



variable length

Properties:

- Lateral mounting due to split hubs
- Spans distances of up to 4 m
- Low moment of inertia
- Vibration damping
- Press fit designs
- Backlash free Line Shaft

Material:

Clamping hub: high strength aluminum.
 Elastomer insert: precision molded wear resistant, and thermally stable polymer.
 Intermediate tubes: precision machined aluminum tube, steel or composite tube are upon request available.

Design:

Two split coupling hubs are concentrically machined with concave driving jaws.
 Both coupling bodies are solid joint by two tubes with high concentricity. While loosening the tube clamping, a length variation is possible within the given range. Elastomer inserts are available in type A or B.

Speed:

To control the critical resonant speed please advise the application speed when ordering or inquiring about EZ Line Shafts.

Tolerance:

On the hub/shaft connection 0.01 to 0.05 mm.

Torsional stiffness:

To optimize the application different elastomer inserts with different shore values are available

Ordering example

EZV / 020 / 1200 / A / 24 / 19.05 / XX

Model	EZV
Series	020
inserted min. length	1200
Type Elastomer insert	A
Bore Ø D1 H7	24
Bore Ø D2 H7	19.05
Non standard e.g. finely balanced	XX

All data is subject to change without notice.

Assembly instructions

After loosening the clamping screws E2, the axial moveable tube ① can be adjusted to the proper position. After reaching the axial position, the clamping bolts must be fastened under notification of the given tightening torque. A high concentricity of the line shaft is guaranteed.

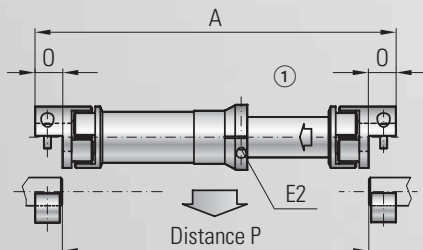

R+W calculation program

With specially developed software R+W can calculate the critical resonant speeds for each application.

Results of a calculation are shown below.

The critical speed can be altered by changing the tube material and/or other parameters.

Critical resonant speed	n_k	=	rpm
Torsional stiffness tube	C_T^{ZWR}	=	Nm/rad
Total stiffness EZV	C_{Tdyn}^{EZ}	=	Nm/rad
Torsional deflection	φ	=	Degree-Min-Sec
Weight of total axes	m	=	kg
Critical resonance speed	n_e	=	rpm
Mass moment of inertia	J	=	kgm ²
Permissible lateral misalignment	ΔKr	=	mm



MODEL EZV

BACKLASH FREE LINE SHAFTS

Model EZV			Series											
			10		20		60		150		300		450	
Type (Elastomer insert)			A	B	A	B	A	B	A	B	A	B		
Rated torque (Nm)	T_{KN}		12.5	16	17	21	60	75	160	200	325	405	530	660
Max. torque* (Nm)	T_{Kmax}		25	32	34	42	120	150	320	400	650	810	1060	1200
Inserted min. length from - to (mm)	A_{min}		150 to 2055		200 to 2075		250 to 2095		300 to 2115		350 to 2130		400 to 2150	
Extended over all length from - to (mm)	A_{max}		190 to 4000		250 to 4000		310 to 4000		370 to 4000		440 to 4000		500 to 4000	
Measurement (mm)	$X1+X2$		110		150		190		230		270		300	
Outer diameter hub (mm)	B_1		32		42		56		66,5		82		102	
Outer diameter tube (mm)	B_2		28		35		50		60		80		90	
Outer diameter middle hub (mm)	B_3		41,5		47		67		77		102		115	
Outer diameter with screwhead (mm)	B_5		32		44,5		57		68		85		105	
Fit length (mm)	C		20		25		40		47		55		65	
Inner diameter possible from \emptyset to \emptyset H7 (mm)	$D_{1/2}$		5 to 16		8 to 25		14 to 32		19 to 35		19 to 45		24 to 60	
Screw (ISO 4762/12.9)	E_1		M4		M5		M6		M8		M10		M12	
Tighting torque of the mounting screw (Nm)	E_1		4		8		15		35		70		120	
Screw (ISO 4762/12.9)	E_2		M4		M4		M5		M6		M8		M10	
Tighting torque of the mounting screw (Nm)	E_2		4		4,5		8		18		35		70	
Distance between centers (mm)	F_1		10,5		15,5		21		24		29		38	
Distance between centers (mm)	F_2		15		18		26		31		41		45	
Distance (mm)	G		7,5		8,5		15		17,5		20		25	
Mounting length (mm)	O		16,6		18,6		32		37		42		52	
Moment of inertia coupling half (10^{-3} kgm ²)	J_1/J_2		0,01		0,02		0,15		0,21		1,02		2,3	
Inertia of tube per meter (10^{-3} kgm ²)	J_3		0,075		0,183		0,66		1,18		2,48		10,6	
Dynamic torsional stiffness of coupling hubs (Nm/rad)	C_{Tdyn}^E		270	825	1270	2220	3970	5950	6700	14650	11850	20200	27700	40600
Torsional stiffness of tube per meter (Nm/rad)	C_T^{ZWR}		321		1530		6632		11810		20230		65340	
Distance between centers (mm)	N		26		33		49		57		67		78	
Length of the couplings (mm)	H		34		46		63		73		86		99	

* (Max. transferable torque of the clamping hub see Elastomer Coupling EKH (Page 8))

1 Nm = 8.85 in lbs

Function

Extended all over length = Inserted min. length x 2 - Measurement (X1 + X2)

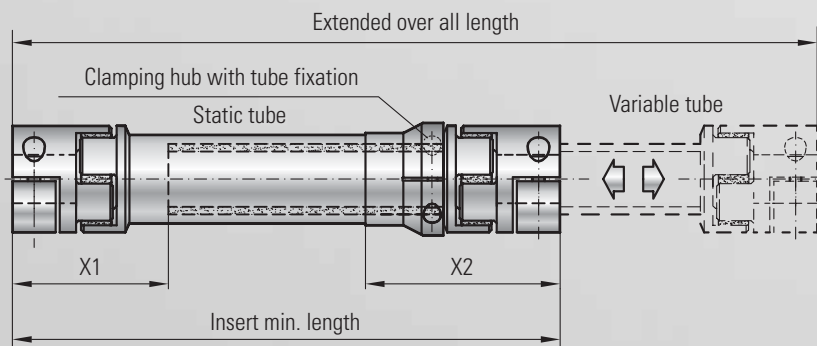

$$\text{Inserted min. length} = \frac{(\text{Extended all over length} + \text{Measurement (X1 + X2)})}{2}$$

The extended over all length and the inserted min. length are related on engineering aspects and design. Depending on the requirements, the coupling can be calculated while using the here shown two formulas to receive its min. and max. dimensions. For Information regarding the design under consideration of axial-, angular-, and lateral torsional stiffness of the EZV, refer to page 15.