

optional
stainless
steel

MODEL BKC

BACKLASH-FREE, TORSIONALLY STIFF METAL BELLOWS COUPLINGS

compact version with clamping hub

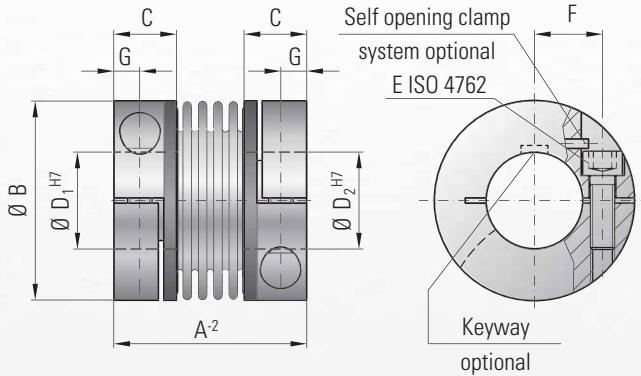

Properties:

- for high speeds
- easy to mount
- suited for space restricted installations
- low moment of inertia

Material:

Bellows made of highly flexible high-grade stainless steel. Hub material see table.

Design:

With a single ISO 4762 radial clamping screw per hub.

Self opening clamp system optional: Loosening the clamping screw applies force to the pin, which will force the clamp into the open position for easy mounting and dismounting.

Absolutely backlash-free due to frictional clamped connection.

Temperature-range:

-30 to +100° C (-22 F to 212 F)

Speeds:

Standard up to 10,000 rpm

Option 1: In excess of 10,000 rpm with a finely balanced version

Option 2: in excess of 30,000 rpm, with balancing grade G = 2.5 (see table)

Service life:

These couplings have an infinite life and are maintenance-free if the technical ratings are not exceeded.

Tolerance:

On the hub/shaft connection 0.01 to 0.05 mm.

Non standard:

Custom designs with varied tolerances, keyways, non-standard material, bellows and ATEX designs are available upon request.

Ordering example

BKC / 60 / 26 / 22 / XX

Model
Series Nm
Ø D1 H7
Ø D2 H7
non standard e.g. stainless steel

Model BKC			Series				
			15	30	60	150	300
Rated torque (Nm)	T_{KN}	18	30	60	150	300	500
Overall length (mm)	A^{-2}	48	58	67	78	94	100
Outer diameter (mm)	B	49	56	66	82	110	123
Fit length (mm)	C	16.5	21	23	27.5	34	34
Inner diameter possible from Ø to Ø H7 (mm)	$D_{1/2}$	8-28	12-32	14-35	19-42	24-60	32-75
Fastening screw ISO 4762		M5	M6	M8	M10	M12	M12
Tightening torque of the fastening screw (Nm)	E	8	15	40	75	120	125
Distance between centers (mm)	F	17.5	20	23	27	39	45
Distance (mm)	G	6.5	7.5	9.5	11	13	13
Moment of inertia (10^{-3} kgm ²)	J_{total}	0.05	0.1	0.26	0.65	6.3	9
Hub material		AL	AL	AL	AL	steel	steel
Approx. weight (kg)		0.13	0.21	0.37	0.72	3.26	3.52
Torsional stiffness (10^3 Nm/rad)	C_T	23	31	72	141	360	410
axial ± (mm)	Max. values	1	1	1.5	2	2	2.5
lateral ± (mm)		0.2	0.2	0.2	0.2	0.2	0.2
angular ± (degree)		1	1	1	1	1	1
axial spring stiffness (N/mm)	C_a	30	50	67	77	112	72
lateral spring stiffness (N/mm)	C_l	315	366	679	960	2940	2200
Speed max. with G = 2.5 balancing (rpm)		80000	70000	60000	50000	40000	30000

(1Nm ≅ 8.85 in lbs)