

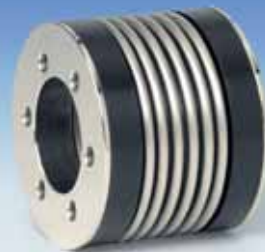

MODEL BK1

TECHNICAL SPECIFICATIONS



with flange mounting

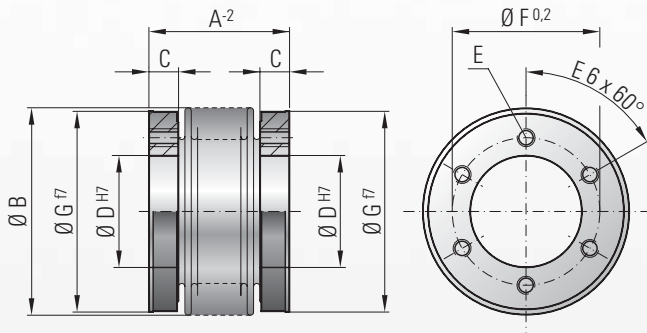

Ordering example

BK1/150 / 62 / XX

Model
Series / Nm
Overall length
Non standard e.g. stainless steel

Properties:

- special design application

Material:

Bellows made of highly flexible high grade stainless steel, hub material: steel

Design:

The Hubs have six threaded metric mounting holes, and the ID and OD are concentrically machined to ISO H7 tolerances.

Hubs with custom bore size, mounting threads and bolt circles are available upon request.

Temperature range:

-30 to +120° C (3.6 F - 270 F)

Speeds:

Up to 10,000 rpm, in excess of 10,000 with finely balanced version.

Service life:

These couplings are maintenance-free if the technical limits are not exceeded

Backlash:

Absolutely backlash-free due to bolted connection.

Brief overloads:

Acceptable up to 1.5 times the value specified.

Non-standard application:

Custom designs with varied tolerances, keyways, non-standard material and bellows are available upon request.

Model BK 1		Series																							
		15		30		60		150		200		300		500		800		1500		4000		6000		10000	
Rated torque (Nm)	T_{KN}	15		30		60		150		200		300		500		800		1500		4000		6000		10000	
Overall length (mm)	A	30	37	36	44	43	53	50	62	53	65	56	70	64	77	81	100	145	138	150					
Outer diameter of bellows (mm)	B	49		55		66		81		90		110		124		133		157		200		253		303	
Fit length/thread depth (mm)	C	7.5		10		11		13		14.5		15		16		18		22		30		30		36	
Inner diameter H7 (mm)	D	25		28		38		50		58		65		70		75		85		100		145		190	
6 x fastening threads	E	M5		M5		M6		M6		M6		M8		M8		M10		M16		M20		8xM20		8xM24	
Hub bolt circle ± 0.2 (mm)	F	35		37		46		62		70		80		94		90		110		140		190		234	
Outer diameter f7 (mm)	G	49		55		66		81		90		110		122		116		140		182		235		295	
Moment of inertia (10 ³ kgm ²)	J_{total}	0.07	0.08	0.14	0.15	0.30	0.32	0.90	0.95	1.30	1.40	1.95	2.10	3.0	3.4	4.3	10.6	46	132	350					
Approx. weight (kg)		0.15		0.2		0.3		0.6		0.8		1.35		1.8		1.9		3.3		8.9		13.9		23.7	
Torsional stiffness (10 ³ Nm/rad)	C_T	20	15	39	28	76	55	175	110	191	140	450	350	510	500	780	1304	3400	5700	10950					
axial (mm)	Max. values	1	2	1	2	1.5	2	2	3	2	3	2.5	3.5	2.5	3.5	3.5	3.5	3.5	3.5	3	3				
lateral (mm)		0.15	0.2	0.2	0.25	0.2	0.25	0.2	0.25	0.25	0.3	0.25	0.3	0.3	0.35	0.35	0.35	0.35	0.4	0.4	0.4				
angular (degree)		1	1.5	1	1.5	1	1.5	1	1.5	1	1.5	1	1.5	1	1.5	1.5	1.5	1.5	1.5	1.5	1.5				
axial spring stiffness (N/mm)	C_a	25	15	50	30	72	48	82	52	90	60	105	71	70	48	100	320	565	1030	985					
lateral spring stiffness (N/mm)	C_r	475	137	900	270	1200	420	1550	435	2040	610	3750	1050	2500	840	2000	3600	6070	19200	21800					

(4Nm = 8.85 in lbs)